

REVISIONS			
DESCRIPTIONS	BY	DATE	APPROVED

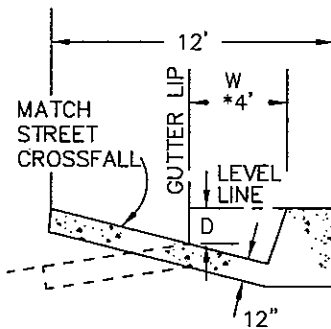
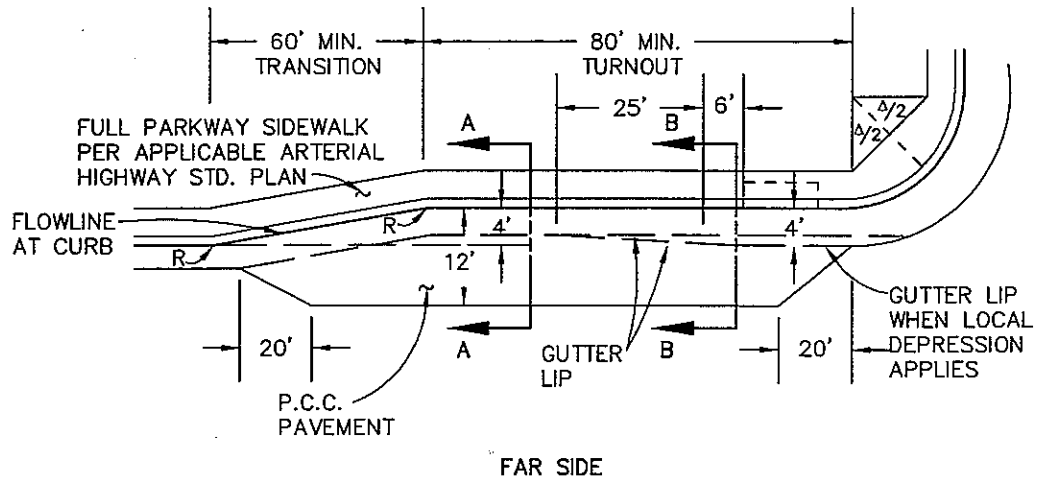

D = 0.50' FOR 8" CURB
 0.38' FOR 6" CURB
 W = 2.0' FOR 8" CURB
 1.50' FOR 6" CURB

*NOTE: 4' WHEN LOCAL DEPRESSION FOR CATCH BASIN APPLIES. SEE LOCAL DEPRESSION PER STD. PLAN 1306 INCLUDING D DIMENSION

SECTION A-A
 SECTION B-B

NOTES

1. R=50'
2. P.C.C. PAVEMENT THICKNESS SHALL BE 12"
3. BUS SHELTERS SHALL BE SET BACK FROM THE FACE OF THE CURB A MINIMUM CLEAR DISTANCE OF FOUR (4) FEET FOR PEDESTRIAN TRAVELWAY.
4. CURB SHALL BE POURED MONOLITHIC WITH P.C.C. PAVEMENT.
5. MODIFICATIONS OF THIS STANDARD SHALL BE REVIEWED FOR ACCEPTABILITY BY THE TRAFFIC ENGINEERING DIVISION.
6. CONSTRUCT CONTROL JOINTS AT 10' INTERVALS.
7. CATCH BASINS SHOULD NOT BE LOCATED IN BUS TURNOUTS IF POSSIBLE.
8. DRIVEWAYS SHOULD NOT BE LOCATED IN BUS TURNOUTS.

DRAWN BY: K.S.R.	CITY OF PASO ROBLES ENGINEERING DIVISION	DRAWING NO.
DESIGNED BY:		
DATE: 00/00/00	BUS TURNOUT	B-4.2
FILE NAME: PR-B-42.DWG		